

# WPD / WPHD

## Woltman meter with impeller axis arranged in parallel to the flow direction

The bulk water meter WPD / WPHD is used to record high flows in drinking water distribution and in industry, with low pressure loss and a predominantly constant flow profile at the same time.

The meter is equipped with a 6-roller dry dial register (IP68) and a modulator disc. This enables electronic, reaction-free scanning and is the basis for remote reading of the meter data via radio with LoRaWAN® or wM-Bus. A combined M-Bus / pulse module is also possible. A mechanical pulser can also be connected in parallel.

All materials, which are used in the drinking water section, comply with the required standards, guidelines and the current German drinking water approval (other country-specific drinking water approvals on request).



### Performance characteristics at a glance

- Woltman parallel type
- WPD (DN 40 - 150), WPHD (DN 200 - 300)
- For horizontal and vertical installation
- Replaceable MID-compliant metrological unit
- Highest precision and reliability even in case of low flow rates
- Flood-proof hermetically sealed glass/copper register (IP68)
- Low starting flow and high overload security
- Wide measuring range, low pressure loss
- Hydraulic bearing relief
- Durable measuring stability
- Swirl-reducing inlet
- No straight inlet or outlet needed (U0/D0) according to OIML R49 and DIN EN ISO 4064
- Optimally equipped for remote readout
- Register rotatable 355°
- Operating pressure MAP 16 (optionally MAP 10)
- Approved in accordance with MID and OIML

### Applications

- For the consumption measurement of cold and clean drinking water or service water up to 50°C
- For measuring high flows

### AMR options

- Can be combined with stationary GSM system
- Retrofittable with EDC module (Electronic Data Capture):
  - EDC- LPWAN radio module (868 MHz) for LoRaWAN®
  - EDC- wireless M-Bus radio module (868 MHz)
  - EDC- combined M-Bus and pulse module

Technical data										
Nominal diameter	DN	mm	40	50	50	50	65	65	80	80
Permanent flowrate	Q <sub>3</sub>	m <sup>3</sup> /h	25	25	40	63	40	63	63	100
Attainable measuring range	Q <sub>3</sub> /Q <sub>1</sub>	R	R160H50V	R200H50V	R315H80V	R315H125V	R200H80V	R315H125V	R315H125V	R315H125V
Standard measuring range <sup>1</sup>	Q <sub>3</sub> /Q <sub>1</sub>	R	R100H50V	R160H50V	R160H63V	R160H63V	R160H63V	R160H63V	R160H63V	R160H63V
Overload flowrate	Q <sub>4</sub>	m <sup>3</sup> /h	31.25	31.25	50	78.75	50	78.75	78.75	125
Minimum flowrate <sup>2</sup>	Q <sub>1</sub>	m <sup>3</sup> /h	0.25/0.5	0.16/0.5	0.25/0.64	0.40/1.0	0.25/0.64	0.40/1.0	0.40/1.0	0.63/1.59
Transitional flowrate <sup>2</sup>	Q <sub>2</sub>	m <sup>3</sup> /h	0.40/0.8	0.25/0.8	0.4/1.02	0.63/1.6	0.4/1.02	0.63/1.6	0.63/1.6	1.0/2.54
Start-up flow rate	-	m <sup>3</sup> /h	0.065	0.065	0.065	0.065	0.065	0.065	0.11	0.11
Display range	min.	l	0.5	0.5	0.5	0.5	0.5	0.5	0.5	0.5
	max.	m <sup>3</sup>	999.999	999.999	999.999	999.999	999.999	999.999	999.999	999.999
Temperature range	-	°C	0.1 - 50	0.1 - 50	0.1 - 50	0.1 - 50	0.1 - 50	0.1 - 50	0.1 - 50	0.1 - 50
Operating pressure	MAP	bar	0.3 - 16	0.3 - 16	0.3 - 16	0.3 - 16	0.3 - 16	0.3 - 16	0.3 - 16	0.3 - 16
Pulse value reed	-	l/pulse	100	100	100	100	100	100	100	100
Pulse value modulator disc	-	l/pulse	10	10	10	10	10	10	10	10
Pressure loss class at Q <sub>3</sub>	Δp	bar	0.63	0.10	0.25	0.63	0.16	0.40	0.10	0.40
Mechanical environmental condition	-	-	M2	M2	M2	M2	M2	M2	M2	M2
Climatic condition <sup>4</sup>	-	°C	5 - 55	5 - 55	5 - 55	5 - 55	5 - 55	5 - 55	5 - 55	5 - 55
Flow profile sensitivity	-	-	U0/D0	U0/D0	U0/D0	U0/D0	U0/D0	U0/D0	U0/D0	U0/D0

Dimensions and weights:										
Nominal diameter	DN	mm	40	50	50	50	65	65	80	80
Overall length <sup>1</sup>	L	mm	300	200/270/ 300	200/270/ 300	200/270/ 300	200/300	200/300	200/225/ 300/350	200/225/ 300/350
Height	H1	mm	135	135	135	135	135	135	143	143
Height	H2	mm	65	75	75	75	85	85	95	95
Total height approx. <sup>3</sup>	H1+H2	mm	200	210	210	210	220	220	238	238
Installation height of the measuring unit	H3	mm	230	230	230	230	230	230	256	256
Flange diameter	D	mm	150	165	165	165	185	185	200	200
Bolt circle diameter	D1	mm	110	125	125	125	145	145	160	160
Number of bolts	-	pcs.	4	4	4	4	4	4	8	8
Bolt size	-	mm	M16	M16	M16	M16	M16	M16	M16	M16
Bolt diameter	-	mm	19	19	19	19	19	19	19	19
Weight approx.	-	kg	8.8	9.1/10.7/ 11.1	9.1/10.7/ 11.1	9.1/10.7/ 11.1	11.8/13.6	11.8/13.6	14.1/13.4/ 15.9/16.8	14.1/13.4/ 15.9/16.8

<sup>1</sup> Other measuring ranges and overall lengths (ISO overall lengths) on request

<sup>2</sup> The data refers to the standard measuring range

<sup>3</sup> Total height WPDE + 20 mm

<sup>4</sup> Condensation possible

Flange according to ISO 7005-2. Other flanges on request

Attention: not all versions are available in all markets

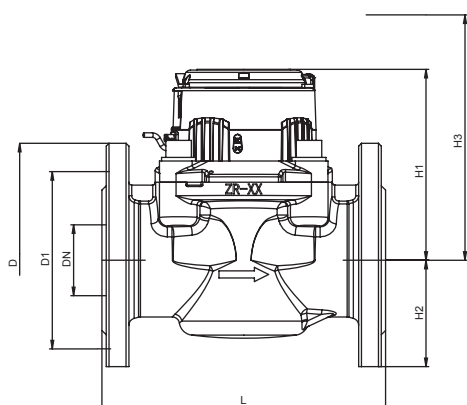

Dimensions WPD

Technical data										
Nominal diameter	DN	mm	80	80	100	100	125	125	150	150
Permanent flowrate	Q <sub>3</sub>	m <sup>3</sup> /h	63	100	100	160	100	160	250	400
Attainable measuring range	Q <sub>3</sub> /Q <sub>1</sub>	R	R315H125V	R315H125V	R315H200V	R315H/315V	R315H200V	R315H/315V	R315H200V	R315H/315V
Standard measuring range <sup>1</sup>	Q <sub>3</sub> /Q <sub>1</sub>	R	R160H63V	R160H63V	R160H63V	R160H63V	R160H63V	R160H63V	R160H63V	R160H63V
Overload flowrate	Q <sub>4</sub>	m <sup>3</sup> /h	78.75	125	125	200	125	200	312.5	500
Minimum flowrate <sup>2</sup>	Q <sub>1</sub>	m <sup>3</sup> /h	0.40/1.0	0.63/1.59	0.63/1.59	1.0/2.54	0.63/1.59	1.0/2.54	1.56/3.97	2.5/6.35
Transitional flowrate <sup>2</sup>	Q <sub>2</sub>	m <sup>3</sup> /h	0.63/1.6	1.0/2.54	1.0/2.54	1.6/4.06	1.0/2.54	1.6/4.06	2.5/6.35	4.0/10.16
Start-up flow rate	-	m <sup>3</sup> /h	0.11	0.11	0.15	0.15	0.15	0.15	0.35	0.35
Display range	min.	l	0.5	0.5	0.5	0.5	0.5	0.5	5	5
	max.	m <sup>3</sup>	999.999	999.999	999.999	999.999	999.999	999.999	999.999 x10	999.999 x10
Temperature range	-	°C	0.1 - 50	0.1 - 50	0.1 - 50	0.1 - 50	0.1 - 50	0.1 - 50	0.1 - 50	0.1 - 50
Operating pressure	MAP	bar	0.3 - 10	0.3 - 10	0.3 - 16	0.3 - 16	0.3 - 16	0.3 - 16	0.3 - 16	0.3 - 16
Pulse value reed	-	l/pulse	100	100	100	100	100	100	1000	1000
Pulse value modulator disc	-	l/pulse	10	10	10	10	10	10	100	100
Pressure loss class at Q <sub>3</sub>	Δp	bar	0.10	0.40	0.16	0.40	0.16	0.40	0.10	0.40
Mechanical environmental condition	-	-	M2	M2	M2	M2	M2	M2	M2	M2
Climatic condition <sup>4</sup>	-	°C	5 - 55	5 - 55	5 - 55	5 - 55	5 - 55	5 - 55	5 - 55	5 - 55
Flow profile sensitivity	-	-	U0/D0	U0/D0	U0/D0	U0/D0	U0/D0	U0/D0	U0/D0	U0/D0

Dimensions and weights:										
Nominal diameter	DN	mm	80	80	100	100	125	125	150	150
Overall length <sup>1</sup>	L	mm	225	225	250/350/ 360	250/350/ 360	250	250	300	300
Height	H1	mm	143	143	152	152	152	152	183	183
Height	H2	mm	95	95	105	105	115	115	135	135
Total height approx. <sup>3</sup>	H1+H2	mm	238	238	257	257	267	267	318	318
Installation height of the measuring unit	H3	mm	256	256	266	266	266	266	373	373
Flange diameter	D	mm	200	200	220	220	250	250	285	285
Bolt circle diameter	D1	mm	160	160	180	180	210	210	240	240
Number of bolts	-	pcs.	4	4	8	8	8	8	8	8
Bolt size	-	mm	M16	M16	M16	M16	M16	M16	M20	M20
Bolt diameter	-	mm	19	19	19	19	19	19	23	23
Weight approx.	-	kg	13.4	13.4	16.9/20.5/ 20.6	16.9/20.5/ 20.6	20.1	20.1	31.5	31.5

<sup>1</sup> Other measuring ranges and overall lengths (ISO overall lengths) on request

<sup>2</sup> The data refers to the standard measuring range

<sup>3</sup> Total height WPDE + 20 mm

<sup>4</sup> Condensation possible

Flange according to ISO 7005-2. Other flanges on request

Attention: not all versions are available in all markets

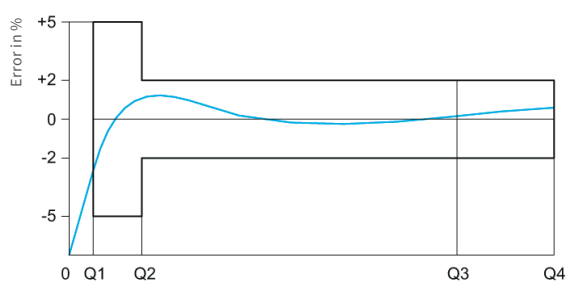

Typical error curve

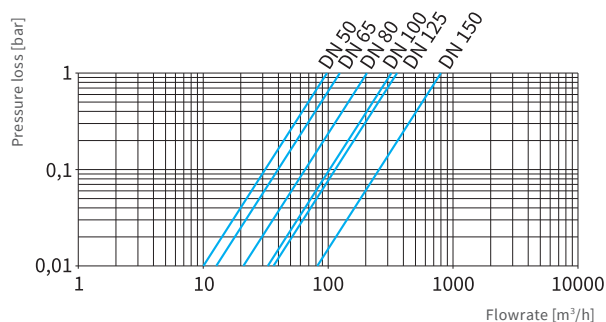

Typical pressure loss curve WPD

# WPHD

## Technical data

Nominal diameter	DN	mm	200	200	250	250	300	300
Permanent flowrate	$Q_3$	$m^3/h$	400	400	630	630	1000	1000
Attainable measuring range	$Q_3/Q_1$	R	R160H125V	R160H125V	R160H125V	R160H125V	R160H125V	R160H125V
Standard measuring range <sup>1</sup>	$Q_3/Q_1$	R	R160H63V	R160H63V	R100H63V	R100H63V	R100H63V	R100H63V
Overload flowrate	$Q_4$	$m^3/h$	500	500	787	787	1250	1250
Minimum flowrate <sup>2</sup>	$Q_1$	$m^3/h$	2.5/6.35	2.5/6.35	6.3/10.0	6.3/10.1	10.0/15.87	10.0/15.88
Transitional flowrate <sup>2</sup>	$Q_2$	$m^3/h$	4.0/10.16	4.0/10.16	10.08/16.0	10.08/16.1	16.0/25.4	16.0/25.5
Start-up flow rate	-	$m^3/h$	2.00	2.00	2.00	2.00	2.00	2.00
Display range	min.	l	5	5	5	5	5	5
	max.	$m^3$	999.999 x10	999.999 x10	999.999 x10	999.999 x10	999.999 x10	999.999 x10
Temperature range	-	°C	0.1 - 50	0.1 - 50	0.1 - 50	0.1 - 50	0.1 - 50	0.1 - 50
Operating pressure	MAP	bar	0.3 - 16	0.3 - 10	0.3 - 16	0.3 - 10	0.3 - 16	0.3 - 10
Pulse value reed	-	l/pulse	1000	1000	1000	1000	1000	1000
Pulse value modulator disc	-	l/pulse	100	100	100	100	100	100
Pressure loss class at $Q_3$	$\Delta p$	bar	0.10	0.10	0.10	0.10	0.10	0.10
Mechanical environmental condition	-	-	M2	M2	M2	M2	M2	M2
Climatic condition <sup>4</sup>	-	°C	5 - 55	5 - 55	5 - 55	5 - 55	5 - 55	5 - 55
Flow profile sensitivity	-	-	U0/D0	U0/D0	U0/D0	U0/D0	U0/D0	U0/D0

## Dimensions and weights:

Nominal diameter	DN	mm	200	200	250	250	300	300
Overall length <sup>1</sup>	L	mm	350	350	450	450	500	500
Height	H1	mm	215	215	267	267	250	250
Height	H2	mm	160	160	193	193	220	220
Total height approx. <sup>3</sup>	H1+H2	mm	375	375	460	460	470	470
Installation height of the measuring unit	H3	mm	460	460	460	460	470	470
Flange diameter	D	mm	340	340	405	395	460	445
Bolt circle diameter	D1	mm	295	295	355	350	410	400
Number of bolts	-	pcs.	12	8	12	12	12	12
Bolt size	-	mm	M20	M20	M24	M20	M24	M20
Bolt diameter	-	mm	23	23	28	23	28	23
Weight approx.	-	kg	49	49	68	68	105	105

<sup>1</sup> Other measuring ranges and overall lengths (ISO overall lengths) on request

<sup>2</sup> The data refers to the standard measuring range

<sup>3</sup> Total height WPHDE + 20 mm

<sup>4</sup> Condensation possible

Flange according to ISO 7005-2. Other flanges on request

Attention: not all versions are available in all markets

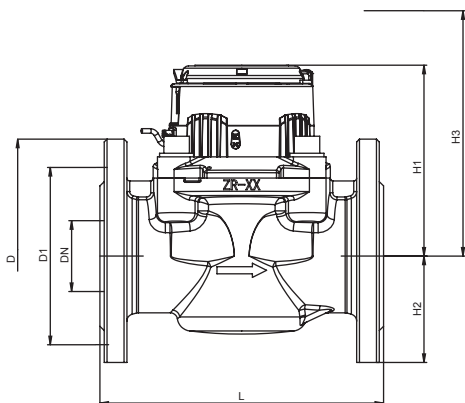

Dimensions WPHD

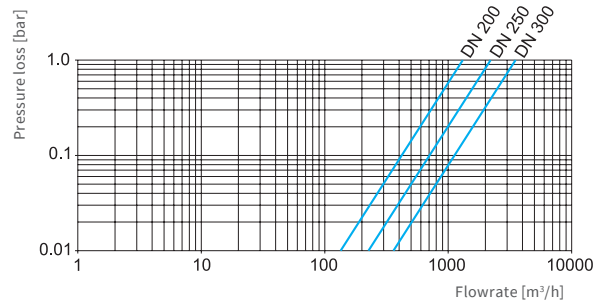

Typical pressure loss curve WPHD

## ZENNER International GmbH & Co. KG

Heinrich-Barth-Straße 29 | 66115 Saarbrücken | Germany

Phone +49 681 99 676-30

Fax +49 681 99 676-3100

E-Mail  
Internet

info@zenner.com

www.zenner.com